

TRBoxter 250 kg - 21 m/min, direct control



Compact electric winch 250 kg. Range of multimultifunctional electric winch offering many rope attachments, rope outlets and options.

Use:

- Lifting and hauling/pulling operations
- High operating factor
- Industry
- Building and public works
- Integration into many types of devices, cranes...
- Pulling carriages or wagons with a two-way system
- Installation and extraction of parts in ovens
- Hanging chandeliers
- Boat haulage
- Doors lifting, traps opening
- Material lifts
- Stage industry
- Swimming pool roofs...

Comply with Machines Directive 2006/42/EC and standard NF E N 14492-1.

Technical properties

- Welded steel drum protected by perforate plate, adjustable according to the outlet of the rope. Large flanges for a large rope capacity.
- Reliable and very safe cable clamp. Caged nut for winch multi-position fixing.
- Aluminium casing.
- Robust and compact, it benefits of a high operating factor.
- Asynchronous, single phase motor 230 V - 50 Hz or three phase motor 230/400 V - 50 Hz depending on models. P = 1,1 kW.
- The direct control is used only with weather protection.
- 230 V single/380 V three-phase remote control depending on models, IP 65 protection.
- Limit switch obligatory when lifting. For three-phase models, it has to be incorporated into the installation otherwise choice will go to a low voltage model.
- Conical brake incorporated into the motor.
- Reducer sealed in oil bath with helical gears.
- Fixation points identical to the TRB model allowing old TRB to be replaced.
- Lengthened drum models: standard length of drum and drum capacity x 1,5.
- Available options: rope press-roller, grooved drum, specific paint, chassis, drum length on request, rain cover, timer, tarpauline cover...

Technical characteristics of TRBoxter 250 kg - 21 m/min, direct control

References	TRBOXTER250CD21
Capacity 1st layer kg	290
Capacity top layer kg	250
Nb of layers	3
Wire rope cap. 1st layer m	16
Wire rope cap. top layer m	56
Wire rope Ø mm	5
Fixed speed 1st layer m/min	19,8
Fixed speed top layer m/min	23
FEM	1Am
Motor kW	1,1
Power	1Ph-230V or 3Ph-230/400 V
Weight (without wire rope) kg	48

Dimensions

References	TRBOXTER250CD21
A mm	462
B mm	243
C mm	79
D mm	Ø 121
E mm	255
F mm	Ø 10,5
L (with limit switch) mm	421
L (without limit switch) mm	356
G mm	197
H mm	243
I mm	68
J mm	23
K mm	356
M mm	121,5
N mm	121,5
T mm	230

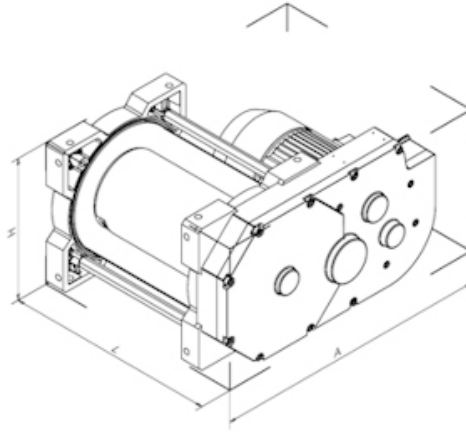
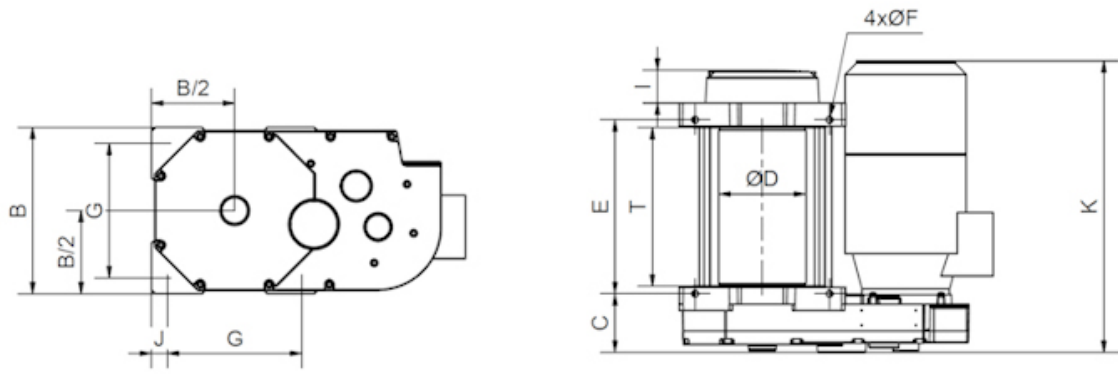

Technical characteristics of the other models of the range

References	TRBOXTER250CD9	TRBOXTER250CD14	TRBOXTER250CD21	TRBOXTER503CD4	TRBOXTER350CD9
Capacity 1st layer kg	290	290	290	600	400
Capacity top layer kg	250	250	250	500	350
Nb of layers	3	3	3	3	3
Wire rope cap. 1st layer m	16	16	16	12	16
Wire rope cap. top layer m	56	56	56	42	56
Wire rope Ø mm	5	5	5	7	5
Fixed speed 1st layer m/min	8,1	13,3	19,8	4	8,1
Fixed speed top layer m/min	9,4	15,4	23	4,9	9,4
FEM	1Am	1Am	1Am	1Bm	1Bm
Motor kW	0,75	0,75	1,1	0,75	0,75
Power	1Ph-230V ou 3Ph-230/400 V	1Ph-230V or 3Ph-230/400 V	1Ph-230V or 3Ph-230/400 V	3Ph-230/400V	1Ph-230V or 3Ph-230/400V
Weight (without wire rope) kg	44	44	48	44	44

References	TRBOXTER350CD14	TRBOXTER503CD11	TRBOXTER600CD5	TRBOXTER800CD5	TRBOXTER990CD5
Capacity 1st layer kg	400	600	750	950	1200
Capacity top layer kg	350	50	600	800	990
Nb of layers	3	3	4	3	3
Wire rope cap. 1st layer m	16	12	19	16,5	14,5
Wire rope cap. top layer m	56	42	93	59	53
Wire rope Ø mm	5	7	7	8	9
Fixed speed 1st layer m/min	13,3	10	4,8	4,3	4,4
Fixed speed top layer m/min	15,4	12,2	6	5,2	5,3
FEM	1Bm	1Bm	1Am	1Bm	1Bm
Motor kW	1,1	1,1	0,75	1,1	1,1
Power	1Ph-230V or 3Ph-230/400 V	1Ph-230V or 3Ph-230/400V	1Ph-230V or 3Ph-230/400V	1Ph-230V or 3Ph-230/400V	1Ph-230V or 3Ph-230/400V
Weight (without wire rope) kg	48	48	88	92	92



HUCHEZ's advice

Fixation points identical to the TRB model allowing old TRB to be replaced, many rope attachments, rope outlets and options.



HUCHEZ
9, Grande Rue
60420 FERRIERES – France
☎ +33 (0) 3 44 51 11 33
Site internet : www.huchez.com
E-mail : contact@huchez.fr



SERVICE
CLIENTS

Pour en savoir plus, n'hésitez pas à nous contacter !
To know more, please contact us!